



Figure 1. 2CH Wireless Switching Actuator
图 1. 无线2路继电器

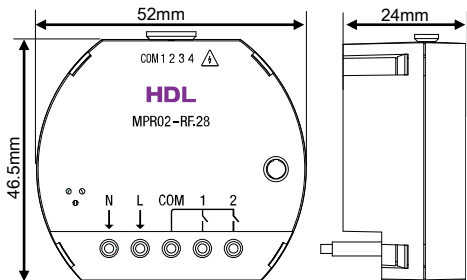

Figure 2. Dimensions - Front View
图 2. 尺寸图 - 正面

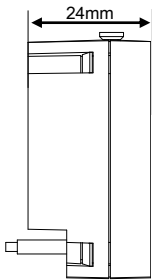

Figure 3. Dimensions - Side View
图 3. 尺寸图 - 侧面

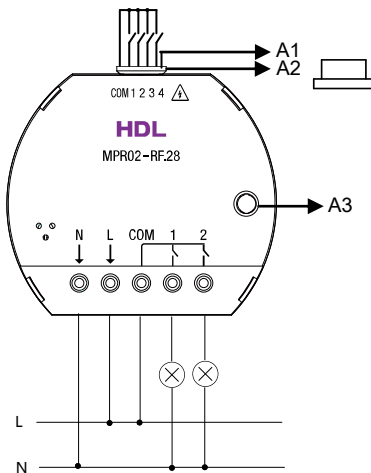

Figure 4. Wiring
图 4. 接线图

Overview

2CH Wireless Switching Actuator (See Figure 1) contains 2-channel relay outputs and 4-channel dry contact. Working with wireless gateway, the actuator can be used for controlling different targets.

Functions

- 2CH relay outputs and 4CH dry contact.
- Supports such functions as switch-on delay, switch-off delay and protection delay.
- 4CH dry contact can be used for controlling targets like dimming and switching, and supports electronic switches and mechanical switches.
- Switching modes supported by dry contact: Mechanical switch, Single on, single off, single on/off, Combination on/off, Multi-function, Parallel switch. (Each switching mode can be set as: Switch on/off, Dim up/ down, Dim up or Dim down.)
- Control targets: Scene, Sequence, Universal switch, Single channel lighting control, Broadcast scene, Broadcast channel, Curtain switch, GPRS control switch, Panel control, Music control.
- Compliant with IEEE.802.15.4 standard.
- Supports online upgrade.
- Supports easy programming via HDL ON APP.

Important Notes

- The subnet ID of the actuator should be the same as that of the wireless gateway.
- To protect the actuator and loads, it is recommended to connect a 10A circuit breaker to each channel.
- The actuator should be installed in wall box and the bottom of panel should be thinner than 20mm.
- Please use the actuator according to technical data.

Product Information

Dimensions - See Figure 2 - 3

Wiring - See Figure 4

- A1: Dry contact
- A2: Silica gel stopper
- A3: Programming button

Programming button: when the device works properly, the green LED flashes. Press the programming button for three times continuously, the green LED flashes quickly, then the device will enter setup mode. (The wireless gateway should be set to setup mode manually at the same time for users to configure parameters.)

Silica gel stopper: used for preventing short circuit caused by contact between power cable or load cable and dry contact. When the device is shipped from factory, the silica gel stopper is installed in the slot. Remove the stopper before wiring. If no wiring, plug the stopper in the slot.

Installation - See Figure 5 - 7

- Install the wall box in the wall.
- Secure the actuator into the wall box after wiring.
- Install the panel on the wall box with screws. The bottom of panel should be thinner than 20mm.

Safety Precautions

- When the device is energized, the dry contact terminals are charged. Please ensure that the connected dry contact is isolated from human body.
- The installation and commissioning of the device must be carried out by HDL or the organization designated by HDL. For planning and construction of electric installations, the relevant guidelines, regulations and standards of the respective country are to be considered.
- The device should be installed in wall box. HDL does not take responsibility for all the consequences caused by installation and wire connection that are not in accordance with this document.
- Please do not privately disassemble the device or change components, otherwise it may cause mechanical failure, electric shock, fire or body injury.
- Please resort to our customer service department or designated agencies for maintenance service. The warranty is not applicable for the product fault caused by private disassembly.

Package Contents

HDL-MPR02-RF.28*1 / Datasheet*1 / Warranty card*1 / Cable (15cm)*1

产品概述

无线2路继电器(见图1)是一款带2路继电器输出和4路干接点的无线设备。与无线网关配合使用可用于控制不同种类的目标。

功能说明

- 2路继电器输出和4路干接点。
- 具有开启延时, 关闭延时, 保护延时功能。
- 4路干接点具有调光功能, 可控目标, 并支持电子开关和机械开关。
- 干接点支持的开关类型: 机械开关、单一开、单一关、单一开-关、组合开、组合关、组合开关、多功能、并联开关(每个开关类型可以设置为开关模式、双向调光、向下调光、向上调光)
- 控制类型: 场景、序列、通用开关、单路调节、广播场景、广播回路、窗帘控制、面板控制、GPRS功能、音乐播放等。
- 无线部分支持标准协议 IEEE.802.15.4
- 支持在线升级。
- 支持HDL ON简易编程。

注意事项

- 2路无线继电器的子网段必须与无线网关的子网段相同。
- 为保护设备及负载建议每回路接一个10A断路器。
- 本设备装入暗盒内, 只能匹配小于20mm厚的面板使用。
- 不得超量程使用。

产品信息

产品尺寸 - 见图 2-3

产品接线 - 见图 4

- A1: 干接点
- A2: 堵孔硅胶
- A3: 编程按钮

编程按钮: 当该设备正常工作时, 绿灯闪烁, 连续点击3次, 绿灯快速闪烁, 进入跳频模式。(无线网关需同时进入跳频模式, 然后才能进行参数配置)

堵孔硅胶: 起绝缘作用, 防止该设备的电源线或负载线与干接点接触造成短路。堵孔硅胶出厂时, 装在排线口里, 若需接排线时, 取下堵孔硅胶; 不接排线时, 则装上。

设备的安装 - 见图 5-7

- 将底盒安装在墙上。
- 将2路无线继电器放入暗盒里。
- 用螺丝将面板安装在暗盒上。面板底部厚度不能超过20mm。

安全警告

- 设备通电时, 干接点端子带电, 请务必确保接入的干接点要与人体隔离。
- 本设备的安装及调试工作必须由我司或我司指派的机构进行。其电气安装的计划 and 施工, 必须遵守当地相关的安全标准和法规。
- 该产品需安装在暗盒内, 未按照本说明书进行安装及接线方式的, 所造成的一切后果皆与我司无关。
- 请不要私自拆装或更换零部件, 否则可能会导致机械故障、电击、火灾或身体伤害。
- 请将一切维修工作交由我司售后部门或指定机构进行, 本产品的保险范围不适用因用户拆卸产品而导致的故障。

装箱清单

HDL-MPR02-RF.28*1 / 说明书*1 / 保修卡*1 / 连接线(15cm)*1

Technical Data

Electrical Parameters

Input voltage	AC100-240V(50/60Hz)
Output current	5A (Resistive load) 2.5A(Capacitive load) Maximum peak inrush-current: 35A
Power consumption	1.45W max.
Communication	Buspro wireless
Wireless transmission power	+10dbm
Wireless sensitivity	-90dbm
Indoor communication distance	≤30m
RSSI Received Signal Strength Indication	>-80dbm

Frequency Allocation

WPAN (China)	780 to 786MHz
SRD (Europe)	864 to 870MHz
ISM (North America)	904 to 928MHz
Default PSK	HDL-SecurityKey0

External Environment

Working temperature	-5°C~45°C
Working relative humidity	≤90%
Storage temperature	-20°C~60°C
Storage relative humidity	≤93%

Specifications

Dimensions	52x46.5x24(mm)
Net weight	45.5g
Housing material	PC, ABS
Installation	Wall box (See Figure 5 - 7)
Protection rating (Compliant with EN 60529)	IP20
Fire and neutral wire	1.5mm ² (the module provides 15cm wire)
Load cable	1.5mm ² (the module provides 15cm wire)
Stripping length	5~7mm

Name and Content of Hazardous Substances in Products

Components	Hazardous substances					
	Lead (Pb)	Mercury (Hg)	Cadmium (Cd)	Chromium VI (Cr (VI))	Poly-brominated biphenyls (PBB)	Poly-brominated diphenyl ethers (PBDE)
Plastic	o	o	o	o	o	o
Hardware	o	o	o	o	-	-
Screw	o	o	o	x	-	-
Solder	x	o	o	o	-	-
PCB	x	o	o	o	o	o
IC	o	o	o	o	x	x

The symbol "-" indicates that the hazardous substance is not contained.

The symbol "o" indicates that the content of the hazardous substances in all the homogeneous materials of the component is below the limit requirement specified in the Standard IEC62321-2015.

The symbol "x" indicates that the content of the hazardous substance in at least one of the homogeneous materials of the part exceeds the limit requirement specified in the Standard IEC62321-2015.

技术参数

电气参数

输入电压	AC100-240V(50/60Hz)
输出电流	5A(阻性负载) 2.5A(容性负载) 峰值电流不超过35A
功耗	1.45W max.
通信协议	Buspro wireless
无线发射功率	+10dbm
无线接收灵敏度	-90dbm
室内通讯距离	≤30m
RSSI接收信号强度	>-80dbm

无线中心频率

中国	WPAN 频段 780至786MHz
欧洲	SRD 频段 864至870MHz
北美	ISM 频段904至928MHz
默认密码	HDL-SecurityKey0

外部环境

工作温度	-5°C~45°C
工作相对湿度	≤90%
储存温度	-20°C~60°C
储存相对湿度	≤93%

产品规格

尺寸	52x46.5x24(mm)
净重	45.5g
外壳材料	PC, ABS
安装方式	暗盒安装 (见图5-7)
防护级别 (符合 EN 60529)	IP20
火零线	1.5mm ² (自带15cm长)
负载线	1.5mm ² (自带15cm长)
剥线长度	5~7mm

产品中有害物质的名称及含量

部件名称	有害物质					
	铅 (Pb)	汞 (Hg)	镉 (Cd)	六价铬 (Cr (VI))	多溴联苯 (PBB)	多溴二苯醚 (PBDE)
塑胶组件	o	o	o	o	o	o
五金铜件	o	o	o	o	-	-
螺丝组件	o	o	o	x	-	-
焊锡	x	o	o	o	-	-
PCB组件	x	o	o	o	o	o
IC	o	o	o	o	x	x

- : 表示不含有该有害物质。

o : 表示该有害物质在该部件所有均质材料中的含量均在IEC62321-2015规定的限量要求以下。

x : 表示该有害物质至少在该部件的某一均质材料中的含量超出IEC62321-2015规定的限量要求。

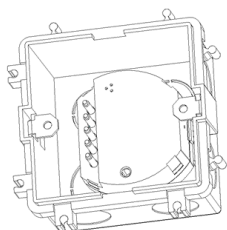

Figure 5 / 图 5

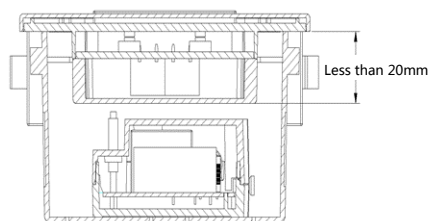

Figure 6 / 图 6

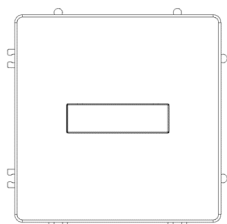

Figure 7 / 图 7

Figure 5 - 7. Installation
图 5 - 7. 安装图

技术支持

服务热线 : 020-85820195

(工作时间 : 9:00-12:00, 13:00-18:00, 星期一至星期五)

邮箱 : kfb@hdlchina.com.cn

网址 : http://www.hdlchina.com

Technical support

E-mail: support@hdlchina.com.cn

Website: https://www.hdlautomation.com

©Copyright by HDL Automation Co., Ltd. All rights reserved.

Specifications subject to change without notice.